

Side to Side Bolted Overhead Cabinet Assembly Instructions

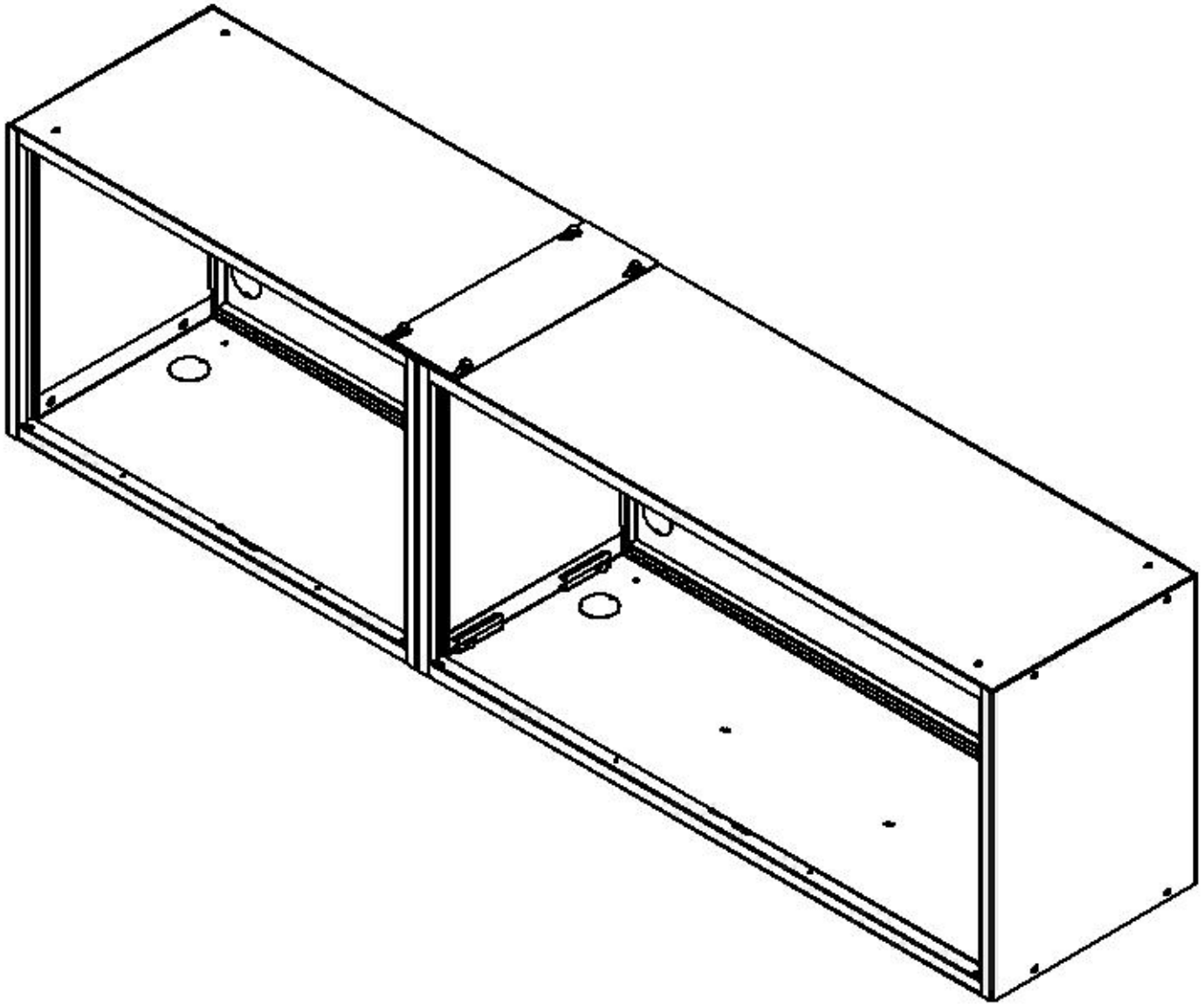

General Information:

The following provides step-by-step instructions for bolting Overhead Cabinets (OHC's) together side by side.

Before Installation:

Before you begin bolting OHC's together side by side read through the entire assembly instructions to familiarize yourself with the assembly process.

When bolting OHC's together side by side it is important to follow the same sequence as described in this manual.

Please review these instructions before beginning assembly procedure.

Notes:

1. These instructions are applicable to all Overhead Cabinets (OHC's)
2. (2) Two people required for assembly
3. Doors have been removed in instructions for **clarity** only.

Tools Required:

- (2) Two Flathead Screwdrivers or object with equivalent shape
- 1/2" Socket
- Socket Wrench
- 1/2" and 7/16" Wrench
- 5/32" and 3/16" Hex Key
- Mallet

1. Disassemble the OHC

A. Remove the center Adjustable Shelf (if included)

1. Locate the tab on the Bracket that holds the Shelf in place
2. Push upward on the shelf enough so that the lock tab can slide under shelf
3. Slide bracket under shelf so that the tab is not visible
4. Rotate shelf upwards and out of slots as shown in Figure 1
5. Remove Shelf from Cabinet

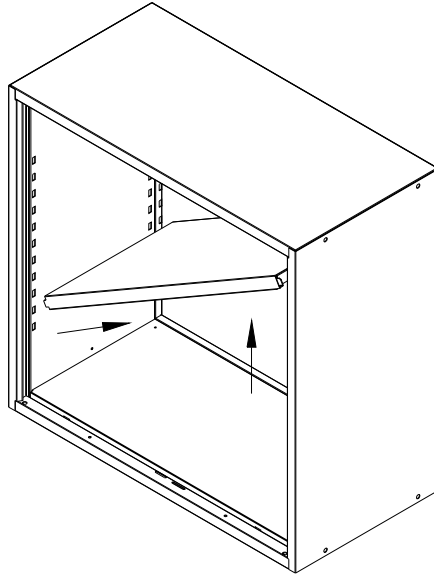

Figure 1 - Adjustable Shelf Removal

B. Remove the Bottom Shelf

1. Insert (1) one Flathead Screwdriver or equivalent into each of the rectangular cutouts in the front of the Bottom Shelf
2. Lift upwards enough so that the Shelf is above the bottom cover of the Cabinet as shown in Figure 2.
3. Remove Bottom Shelf from Cabinet

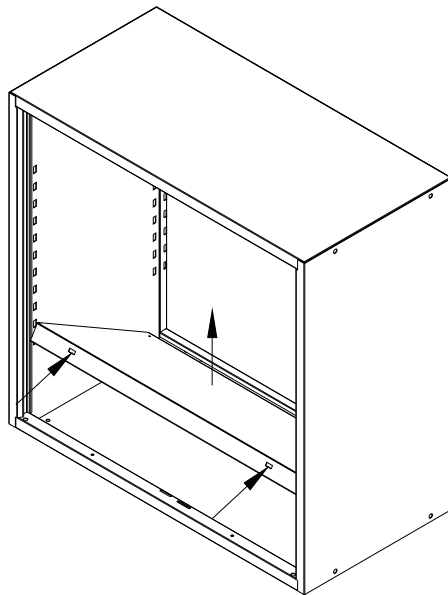

Figure 2 - Bottom Shelf Removal

3. Punch out all required Top Cover and Bottom Side Knockouts (see Fig. 3) towards inside of the cabinet using a mallet and flat head screwdriver (Punch out the knockouts that will be on the “seam” where two Cabinets meet together only. Do not punch knockouts that will not be against another OHC).

A. Also, determine which Wire Passage (large) Knockouts will be used, if any, and punch them out towards inside of Cabinet or bottom side of Shelf

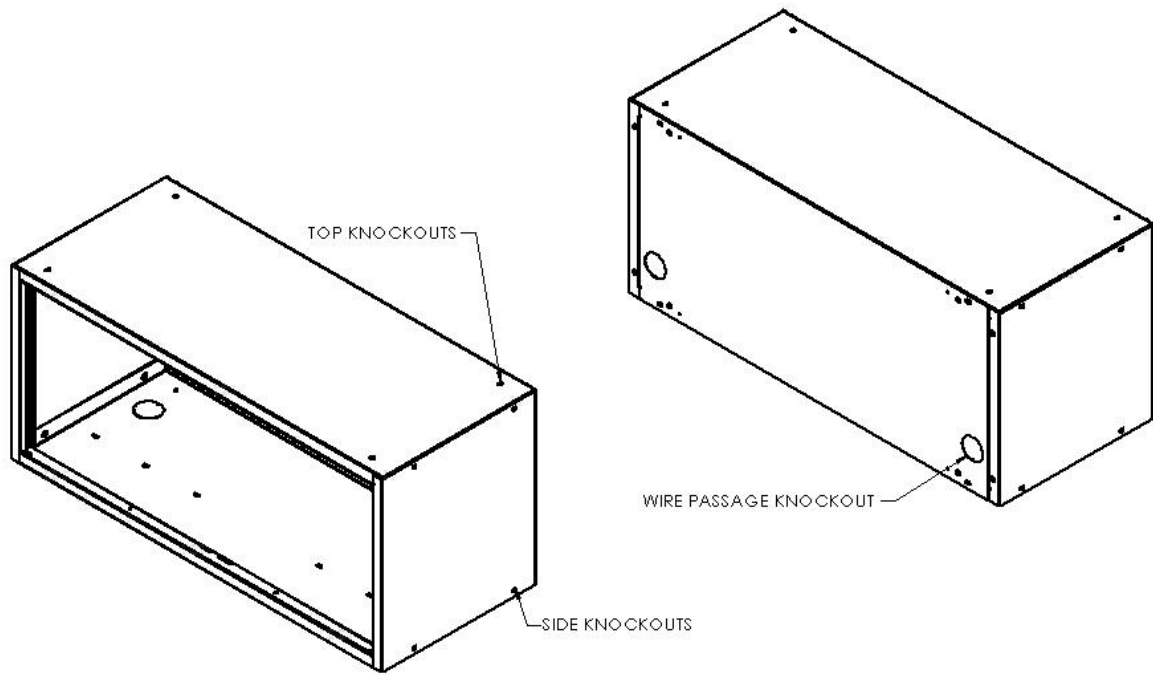

Figure 3 – Knockout Removal

4. Install Top Connecting Plate to Nut Plate
- A. Position Connecting Plate on top seam between Cabinets and align angled slots over knocked out holes. Locate Plate so “angled” portion of slot is towards front of Cabinet as shown in Fig. 4.
 - B. Locate (1) Nut Plate into inside top of OHC with threaded inserts and flanges pointing down as shown in Fig. 4
 - C. Align threaded inserts with knocked out holes in top of OHC
- Note: For OHC with a Retractable Door:
- 1. Lift door up and hold in place (do not push door into the cabinet)
 - 2. Locate one end of Nut Plate inside top front of OHC by sliding it under galvanized hat bracket attached to top of door then follow steps B and C
- D. Screw (4) 5/16-18 x 5/8” Button Head Bolts through Connecting Plate OHC Top and into Nut Plate as far as possible by hand.
 - E. Repeat for all Cabinet connections.
 - F. Slide Connecting Plate forward on Cabinets by tapping with a mallet or using a clamp to pull the Connecting Plate forward until the Connecting Plate is fully engaged with Bolts (as far forward as it will come).
 - G. Tighten all hardware.
 - H. Repeat for all Cabinet connections.

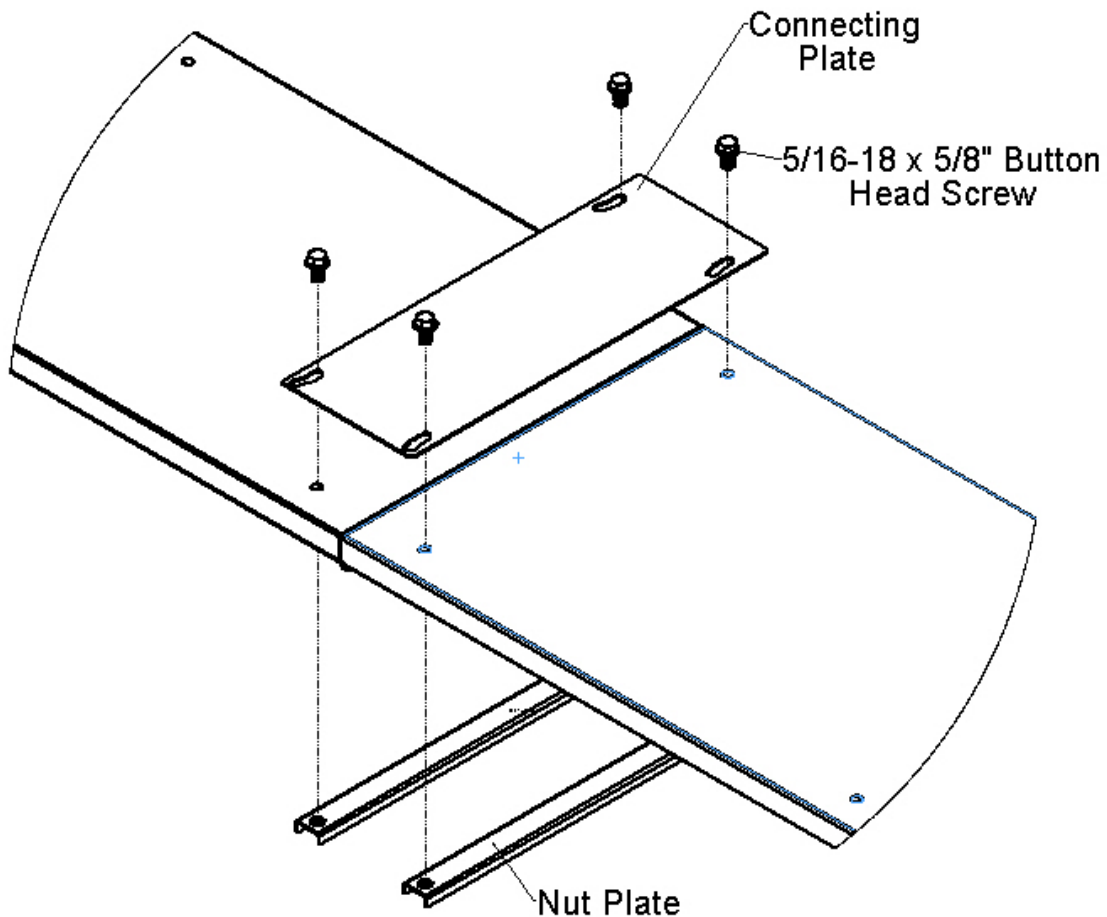

Figure 4 - OHC Top Connecting Plate to Nut Plate

5. Install Side to Side Mounting Hardware at Bottom (Inside Side Panels do not need to be removed)
- A. Mount 5/16" Washer and Support Post onto 5/16-18 x 1-3/4" Hex Bolt.
 - B. From the left, install Bolt, Washer and Support Post though lower front knocked out hole in Cabinets, oriented as shown in Fig. 6.
 - C. Install opposite Support Post onto 5/16-18 x 1-3/4" Hex Bolt, orient as shown in Fig. 5.
 - D. Thread 5/16-18 Lock Top Nut onto 5/16-18 x 1-3/4" Hex Bolt as far as possible by hand.
 - E. Repeat for rear knocked out hole, orient as shown in Fig. 5.
 - F. Repeat for additional cabinets as needed.
 - G. Tighten 5/16-18 hardware for all connections.

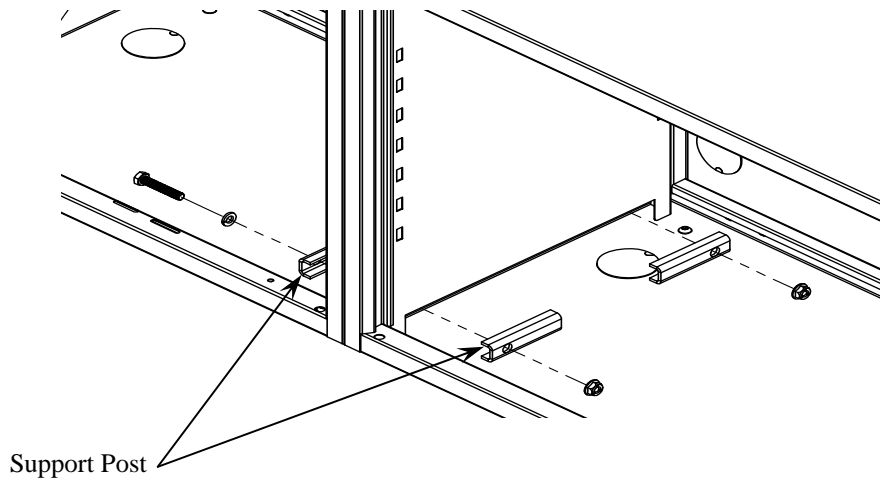
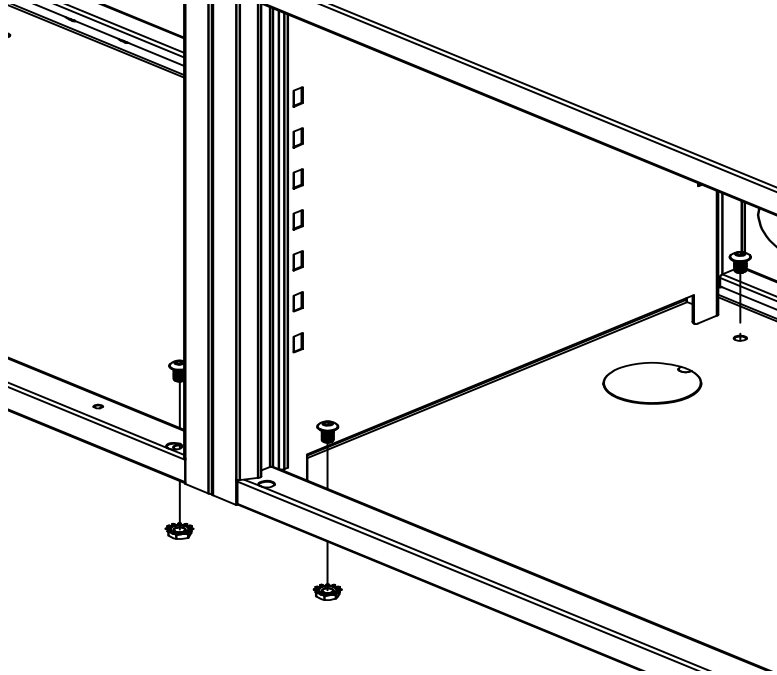

Figure 5 - OHC Lower Side to Side Attachment

6. Attach Overhead Cabinet to Stationary Riser Shelf (if necessary) (see Fig. 6)
 - A. Place Overhead Cabinet(s) on top of Stationary Riser Shelf and align mounting holes
 - B. Insert 1/4-20 x 1/2" Button Head Socket Screw through mounting holes
 - C. Thread 1/4-20 Kep Nut onto 1/4-20 x 1/2" Button Head Socket Screw and loosely tighten (until all hardware is loosely installed).
 - D. When all hardware is installed tighten hardware.



(SRS not shown)

Figure 6 - OHC to SRS Attachment

Notes:

- (2) Two people are required to install the hardware into both Cabinets
 - All steps are starting from the "left" Cabinet moving into the "right" Cabinet
 - Loosely connect all hardware until side by side mounting is finished, then tighten all Nuts and Bolts
 - Brackets face inwards to the Cabinet, they will not fit if reversed
- The (2) Two flanges of the Support Bracket will face the Housing wall, the flat face will face the Washer as in Figure 6

Re-Assembly of OHC

- A. Check the alignment of the Cabinets to make sure they are flush all around
- B. Tighten all Support Bracket Hardware
- C. Repeat Disassemble Instructions in reverse order to Re-Assemble OHC



Making Workspace Work™ is a trademark of Lista International Corporation.

Document Number: SA001A3 Rev 2

Print Date: May 2006

These instructions and other assembly instructions may be found on Lista International Corporation's web site, <http://www.listaintl.com>. For questions or Technical Support, please call 1-800-722-3020

This manual is proprietary information of Lista International Corporation. Unauthorized reproduction of any portion of this manual is prohibited without the written consent of Lista International Corporation. The material in this manual is for informational purposes only. It is subject to change without notice. Lista International Corporation assumes no responsibility for any typographical errors contained in this manual.

Lista International Corporation
106 Lowland Street
Holliston, MA 01746-2094
Toll Free: (800) 722-3020
Phone: (508) 429-1350
E-mail: sales@listaintl.com
Web: <http://www.listaintl.com/>

ISO 9001 Certified

© 2006 Lista International Corporation
All rights reserved.