

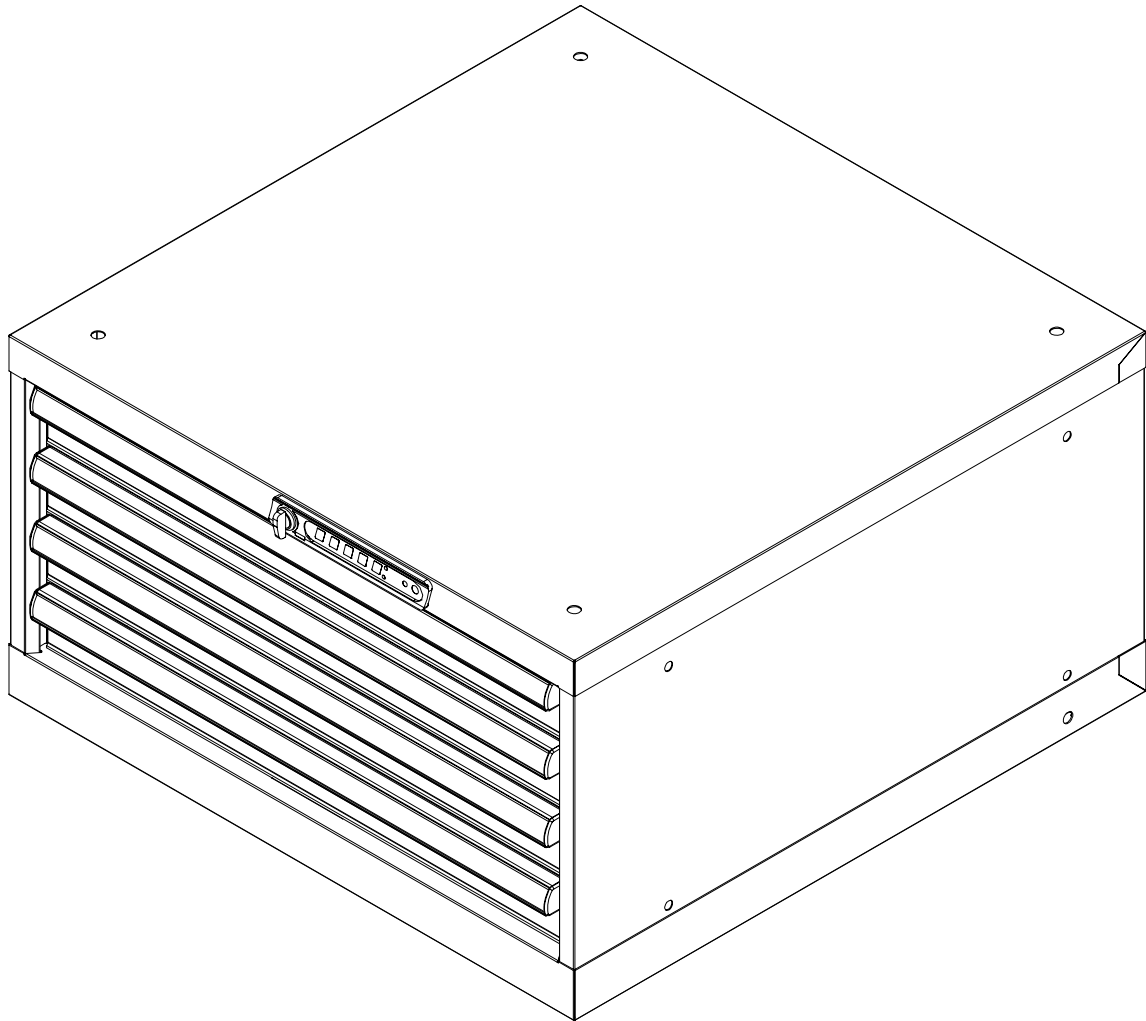

# KEYPAD LOCK USERS MANUAL



**READ ALL INSTRUCTIONS CLOSELY PRIOR TO USE  
SAVE THESE INSTRUCTIONS**

## CONTENTS

---

Keypad Parts and Features	2	Programming the Master Code	3
Programming User Codes	4	Using Your Keypad	5
Changing the Batteries	6	Deleting Codes	8
Emergency Power Override	9	Keypad Care	10
Troubleshooting	11		

# Keypad Parts and Features

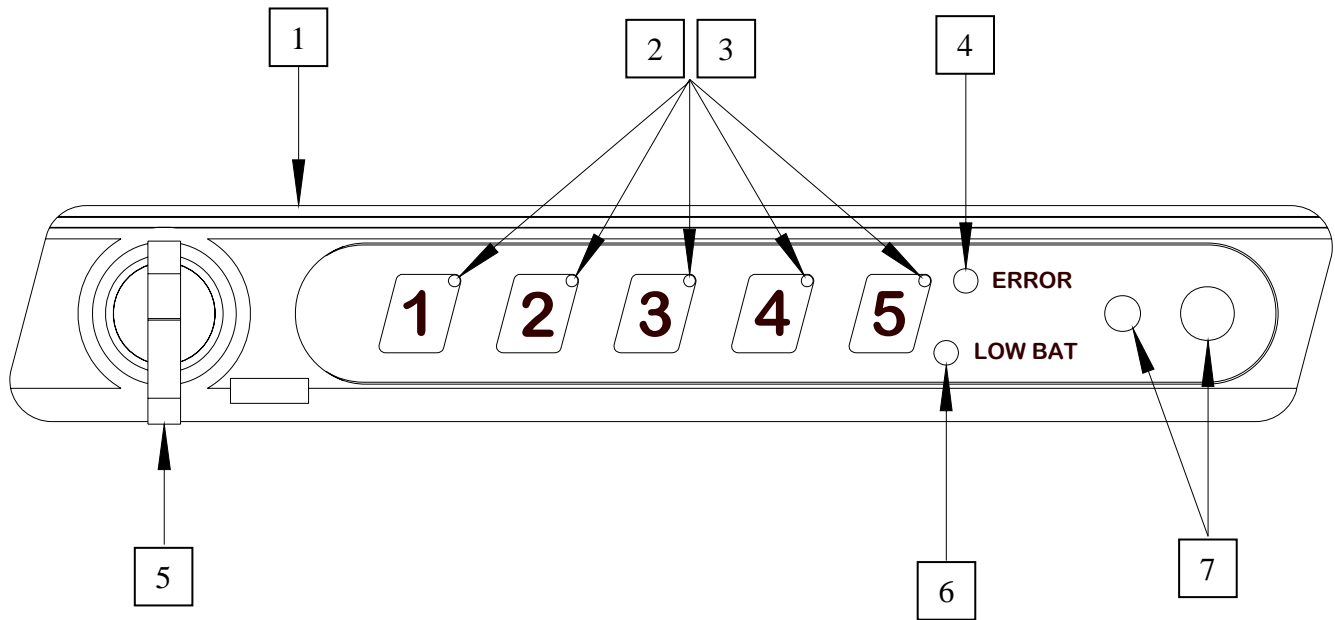

Figure 1

1	Keypad / Faceplate	2	Indicator LEDs
3	Number Buttons	4	ERROR Indicator
5	Lock Knob	6	Low Battery Indicator
7	Emergency Back-up Power Pads		

## Pre-Programmed Codes

**1-1-1-1-1** User Code #1 is pre-programmed for initial cabinet access only and should be reprogrammed once this user's manual is retrieved, prior to using the cabinet. Up to five user codes can be programmed at any given time.

**1-2-3-4-5** This code is the **factory code**. Use this factory code to program your own, unique, **master code**, which is required for programming all user codes. The factory code immediately becomes an invalid code. Neither the factory code, nor the master code provide access to the cabinet – they are for programming only.

## Programming the Master Code

The factory code **1-2-3-4-5** is required in order to program a unique, valid, master code. This master code **DOES NOT** give access to the cabinet - it is for programming only. **DO NOT GIVE YOUR MASTER CODE TO ANYONE.** Once the master code is compromised, the cabinet security is compromised.

**If the cabinet has been unwrapped before it reaches the end user (supervisor), please refer to the section on *Resetting the Master Code* (under the section *Deleting Codes*) prior to programming the new master code. Resetting the keypad, prior to programming any codes, is strongly recommended.**

1. The programming button is an unmarked, hidden, button. It is located between the **ERROR** and **LOW BAT** text on the keypad as shown below in Figure 2.

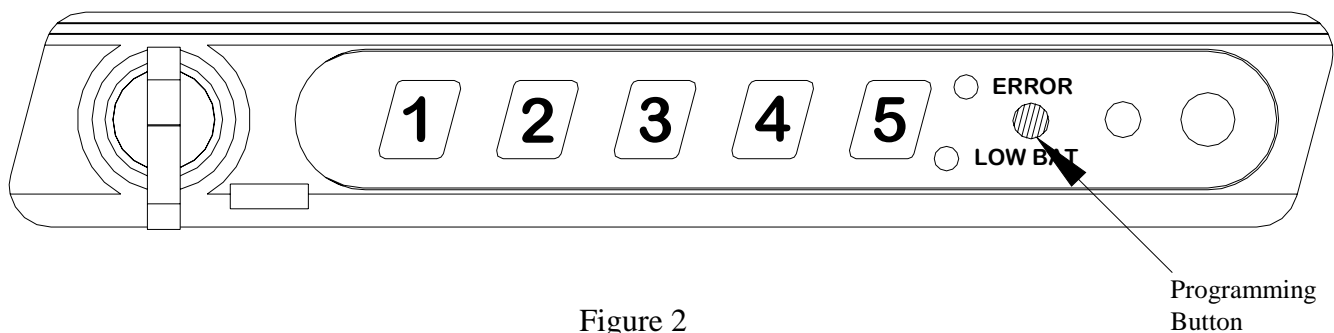

Figure 2

2. Press and hold the programming button for roughly 2-4 seconds, until the **ERROR** LED lights up.
3. Release the programming button. The **ERROR** LED will stay on for 10 seconds waiting for the code. If no code is entered within 10 seconds the LED will flash twice and exit programming mode.
4. Enter the factory code, **1-2-3-4-5**. The indicator LEDs light up, one at a time, from left to right, each time a button is pressed.
  - ◆ Code entered correctly – the **ERROR** LED will flash **once** then all LEDs turn off and the keypad waits for the next step.
  - ◆ Code entered incorrectly – the **ERROR** LED flashes **twice** then all LEDs turn off and the keypad exits programming mode.
5. Press the programming button again for roughly 2-4 seconds, until all the LEDs light up. If nothing is pressed within 10 seconds, the **ERROR** LED will flash three times and the keypad exits programming mode.
6. Enter your new 5-digit master code. The indicator LEDs turn off, one at a time, from left to right, as each button is pressed.
  - ◆ Valid master code entered - LEDs will strobe after the 5<sup>th</sup> entry to confirm acceptance of the code and the keypad exits programming mode.
  - ◆ Invalid master code entered – **ERROR** LED flashes and the keypad exits programming mode.
7. Refer to the section on *Programming User Codes*, Page 4, to test out your new master code.

**Note: Once the new master code is programmed the 1-2-3-4-5 factory code is invalid.**

## **Programming User Codes**

The master code you just programmed is required in order to add or modify any user code. While there are thousands of possible codes, only 5 user codes can be programmed at any given time.

1. Unlock the cabinet using the initial **1-1-1-1** user code and open the top drawer slightly (so when you have finished programming a user code you can test it to make sure that it is correct without locking yourself out of the cabinet).
2. Press and hold the programming button (shown in Figure 2 on the previous page) for roughly 2-4 seconds, until the red **ERROR** LED lights up - you are now in programming mode.
3. Release the programming button. The red **ERROR** LED will stay on for 10 seconds waiting for a valid master code. If no code is entered within 10 seconds the LED will flash 3 times and exit programming mode.
4. Enter the master code. The indicator LEDs light up, one at a time, from left to right, each time a button is pressed.
  - ◆ If an invalid master code is entered the **ERROR** LED will flash twice and the keypad exits programming mode.
  - ◆ If a valid master code is entered the indicator LEDs will flash to indicate acceptance. All LEDs then turn off.
5. Press the button of the user number (1-5) that you want to program. The LED for that number will flash 3 times and the **ERROR** LED will light up.
6. Enter the new 5-digit user code. The indicator LEDs light up one at a time, from left to right, as each button is pressed and then strobe after the 5<sup>th</sup> entry to confirm acceptance of the user code. The keypad exits programming mode.
7. Enter the new user code to ensure that it is correct (the indicator LEDs will strobe and the user number will light up for approximately 2-4 seconds).
8. Repeat Steps 2-7 to program up to 5 user codes.

## Using your Keypad

User Code #1 is pre-set to **1-1-1-1-1**. This is for initial cabinet access only and should be reprogrammed prior to cabinet use.

**Always make sure that the lock knob is in the vertical starting position by turning it as far counter-clockwise as it will go. After entering your code make sure you wait until the indicator LED turns on before you turn the lock knob otherwise you could bind the lock and prevent it from opening.**

1. Key in your 5-digit user code by pressing one button at a time.
2. One indicator LED will light up every time a button is pressed. The LEDs always light up one at a time, from left to right. They do not correspond to the button being pressed so your user code is not displayed to others as it is entered.

Valid User Code - Indicator LEDs strobe and the LED corresponding to the user (1-5) remains lit while the lock is energized (3-4 seconds).

Invalid User Code - Red **ERROR** indicator flashes 3 times and lock does not energize.

The keypad will wait 10 seconds for the next input (press of a button). If it does not detect another input within that time, it will flash the red **ERROR** LED 3 times. You will have to re-enter the user code from the start (all 5 digits again).

3. Turn lock knob 90° clockwise (CW) to open the cabinet.
4. Close all drawers and turn lock knob 90° counter-clockwise (CCW) to re-lock the cabinet.

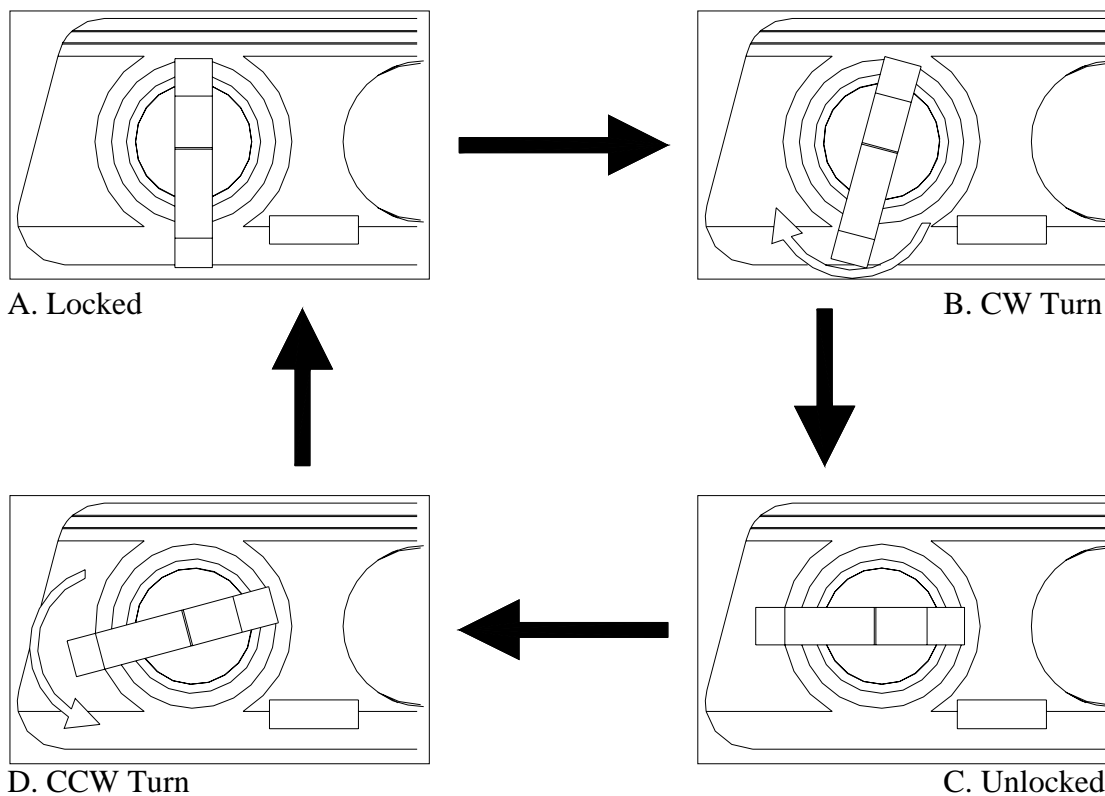

Figure 3

## Changing the Batteries

When the batteries are low, the **LOW BAT** LED will flash 7 times immediately after a correct user code is entered and the lock is energized. It is best to change the batteries before they drain completely, otherwise the procedure for *Emergency Power Override*, Page 9, must be followed.

1. Enter a valid 5-digit user code and turn the lock knob 90° clockwise to unlock the cabinet.
2. Remove the top drawer(s), enough for easy access, as shown in Figure 4. For multiple drawers, the cabinet will have to be locked and unlocked in between drawers due to Lista's PrevenTip® one-drawer-at-a-time feature.
3. Locate the electronics plate in the top of the cabinet as shown below in Figure 4. There is a screw on the rear-most section of this plate that holds a small galvanized mounting bracket over the ledge in the cabinet, Figure 4. Loosen this screw so that the electronics plate is free to move. A 5/32" Allen key might be needed to get the screw spinning freely.

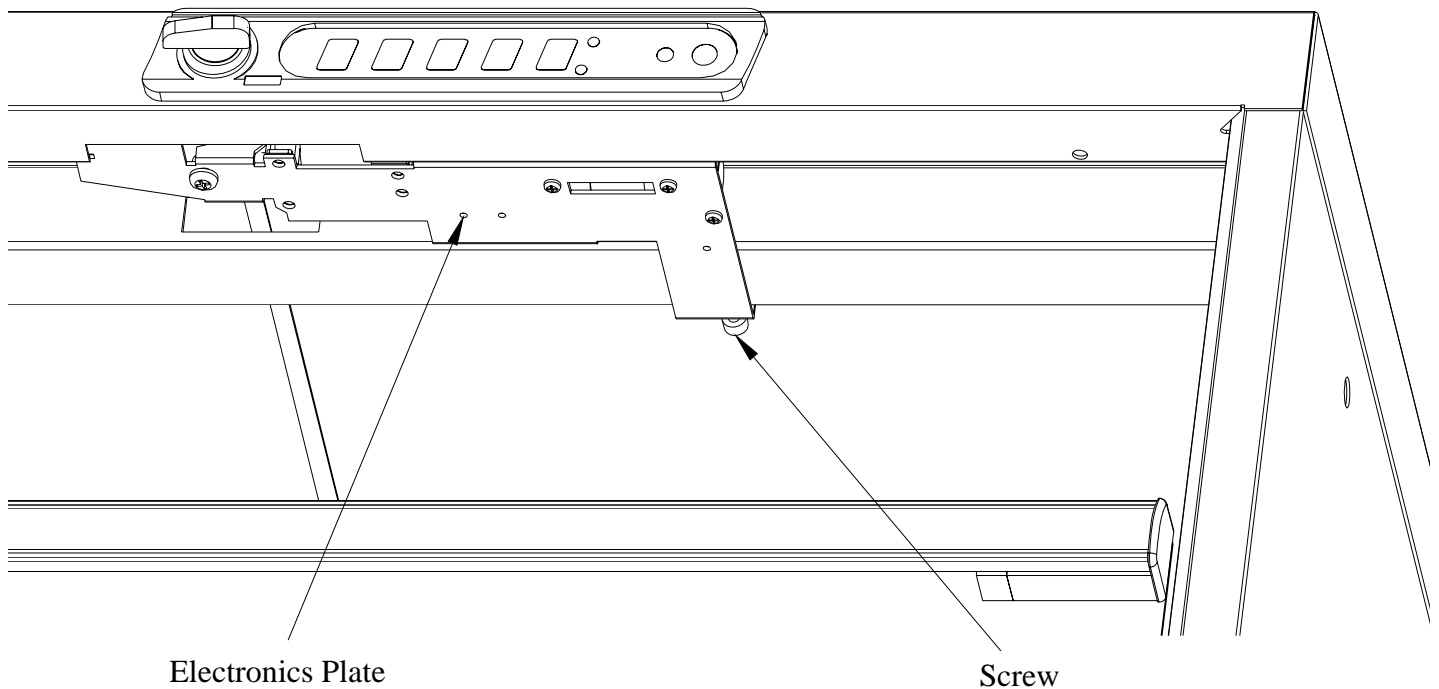

Figure 4

4. Rotate the electronics plate down into the cabinet as shown in Figure 5.
5. Lift out the battery pack and disconnect it from the electronics, Figure 6.
6. This keypad lock uses four (4) AA batteries. Replace all 4 batteries, making sure the polarity of each is correct as shown in Figure 7.
7. Reconnect the battery pack and place it back into the electronics plate (you may need to use a little force to ensure it is fully seated).
8. Rotate the electronics plate back up into the top of the cabinet. Hook the mounting bracket over the ledge in the cabinet.
9. Tighten the screw until it bottoms out to secure the bracket and electronics plate firmly in place.

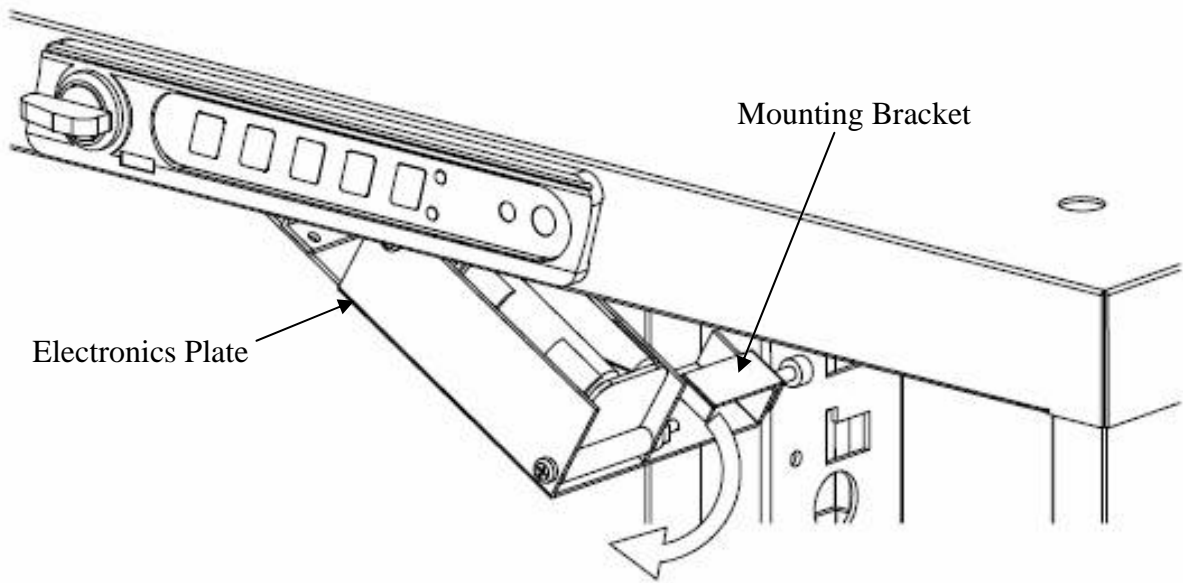

Figure 5

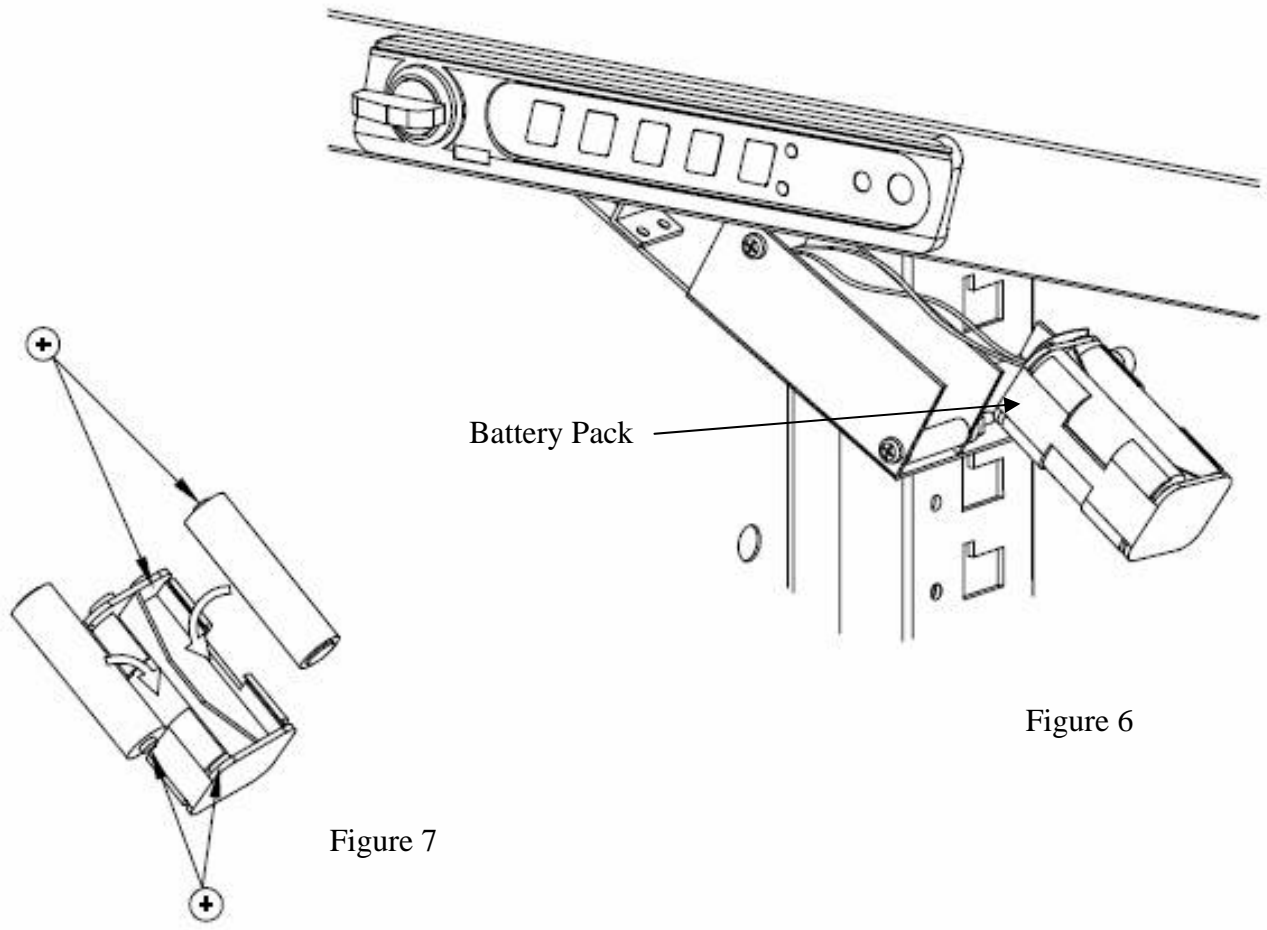

Figure 6

Figure 7

# Deleting Codes

## Individual User Codes

Individual user codes are erased by programming a new user code over them. See *Programming User Codes*, Page 4.

## Master Code

The master code can only be erased by following the reset instructions below. It cannot be programmed over like the user codes.

### Resetting the Master Code and Deleting All User Codes Simultaneously

1. Disconnect the battery pack to power down the keypad. See *Changing the Batteries*, Page 6, for instructions on how to access the battery pack.
2. Press and hold the Programming button. No LEDs will light up.
3. Reconnect the battery pack (keeping the Programming button pressed).
4. All LEDs will flash 5 times to indicate that all programmed user codes and the master code have been erased.
5. Secure the battery pack in place as described in the section, *Changing the Batteries*, Page 6, and replace the drawers in cabinet.
6. Do not lock the cabinet. The master code defaults back to the factory code, **1-2-3-4-5**. Refer to the sections on *Programming the Master Code*, Page 3, and *Programming User Codes*, Page 4, to reprogram the master code and at least one user code prior to locking the cabinet.

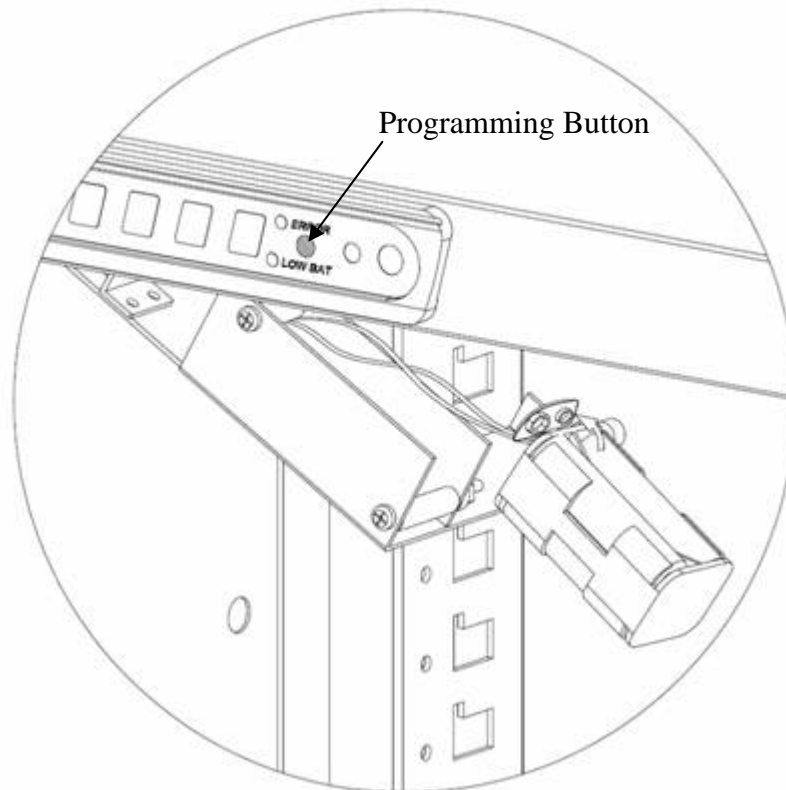

Figure 8

## **Emergency Power Override**

The emergency power override feature is available in the event that the batteries are completely drained and as a result, you cannot unlock your cabinet.

1. Peel the gray protective covering off the two emergency backup pads as shown in Figure 9 below. A sharp-tipped object will help get the covers started.
2. Place the leads of a working 9V battery on the exposed pads and press firmly. Match the larger lead with the larger pad and the smaller lead with the smaller pad, Figure 10. Hold the battery firmly in place.
3. Enter a valid 5-digit user code.
4. Wait as the LEDs scroll to indicate acceptance - the lock will then energize.
5. Turn the lock knob 90° clockwise to open the cabinet.
6. Remove the 9V battery from the emergency power pads.

### **Note:**

The protective peel-off covering is not re-usable and the pads will remain exposed to the environment. The pads can be cleaned off, if necessary, for future use with a pink pencil eraser.

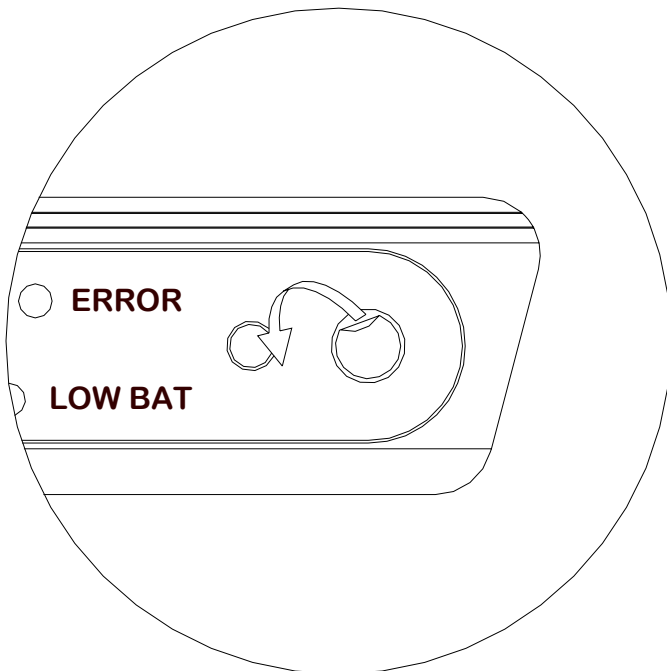

Figure 9

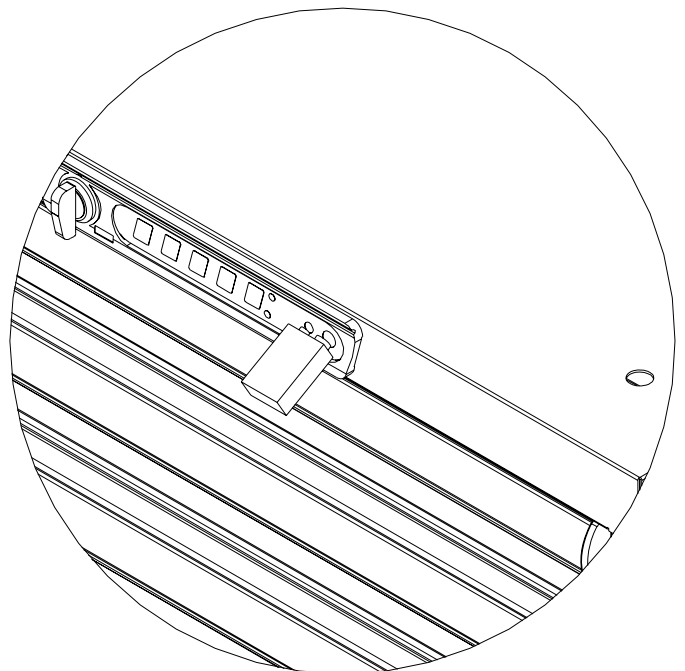

Figure 10

## **Keypad Care**

The keypad may be cleaned using a soft, slightly dampened, cloth and mild soap or detergent if necessary.

Do not use abrasive cleaners or chemical cleaning agents, which might ruin the surface of the keypad.

Do not pour or spill liquids on the keypad.

## Troubleshooting

Symptom	Problem	Solution
No LEDs light up when I enter my code	Batteries are either dead or installed incorrectly	Use 9V battery and follow <i>Emergency Power Override</i> procedure on Page 9
The LOW BAT LED flashes after I enter my code	Batteries are getting low	Refer to the section on <i>Changing the Batteries</i> on Page 6
The ERROR LED flashes after I enter my code	Incorrect user code entered	Follow the instructions on <i>Using Your Keypad</i> on Page 5
	User Code forgotten	Reprogram the user code -see <i>Programming User Codes</i> on Page 4
The LEDs strobe and my user number lights up but lock knob will not turn	Lock mechanism is 'stuck'	Wait until the LED goes out. Turn the lock knob counter-clockwise as far as it will go to make sure it is in the vertical starting position. Re-enter user code and wait for the LED to turn on before turning the lock knob.
The ERROR LED flashes after entering the master code	Master code entered as user code	Master code is <u>not</u> a valid user code. Try opening the cabinet with one of the programmed user codes
	Incorrect master code entered	Follow the <i>Programming User Codes</i> procedure on Page 4 and re-enter master code
	Master code forgotten	Access the cabinet with a valid user code then follow the <i>Deleting Codes</i> procedure on Page 8 to reset the master code. Refer to the sections on <i>Programming the Master Code</i> on Page 3 and <i>Programming User Codes</i> on Page 4 to reprogram the necessary codes.

Making Workspace Work ® is a trade mark of Lista International Corporation

Revision Date: 10-30-2008

Document Number: MD049A3 Rev. 4

This document is proprietary information of Lista International Corporation. Unauthorized reproduction of any portion of this document is prohibited without written consent of Lista International Corporation. The material in this document is for informational purposes only. It is subject to change without notice.

© 2008 Lista International Corporation  
106 Lowland Street  
Holliston, MA 01746-2094  
E-mail: [sales@listaintl.com](mailto:sales@listaintl.com)

All rights reserved

For questions or technical support call **1-800-722-3020**

