

# Assembly Instructions

## *Above Worksurface Riser Shelf Systems and Back / End Stops*

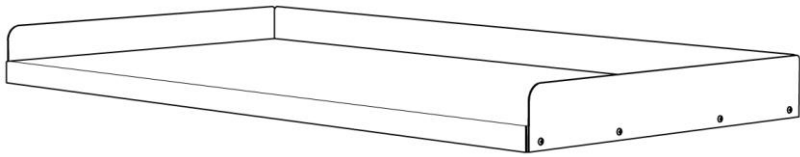

① Back Stops and End Stops

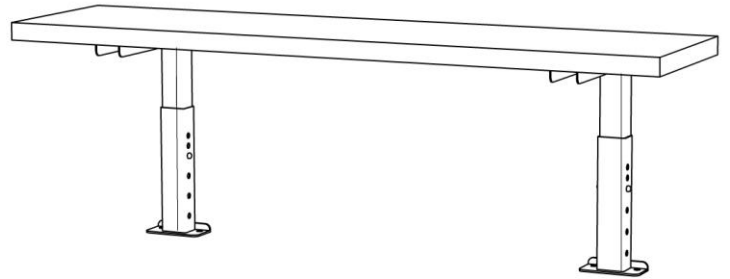

② Adjustable Riser Shelves

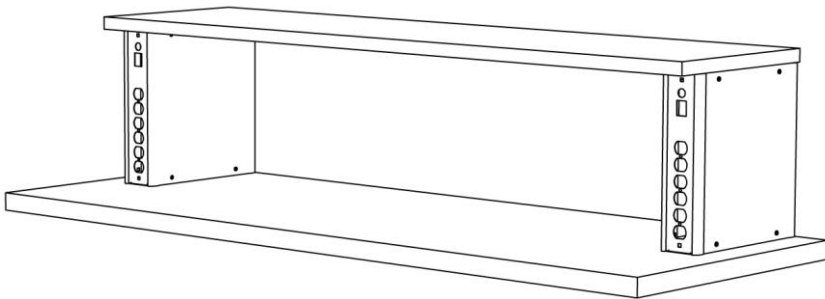

③ Instrument Riser Shelves

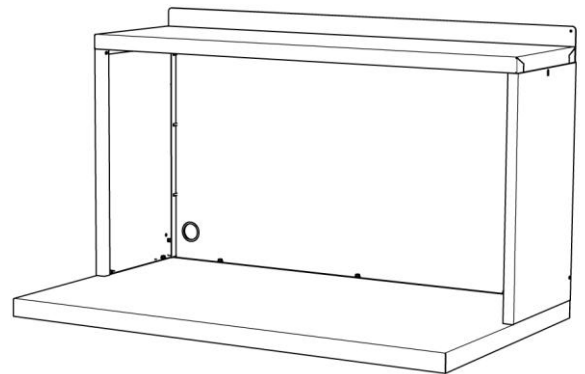

④ Stationary Riser Shelves

### **IMPORTANT**

**PLEASE READ THESE INSTRUCTIONS BEFORE BEGINNING INSTALLATION PROCEDURE**

## 1. Assembling Back Stops and End Stops

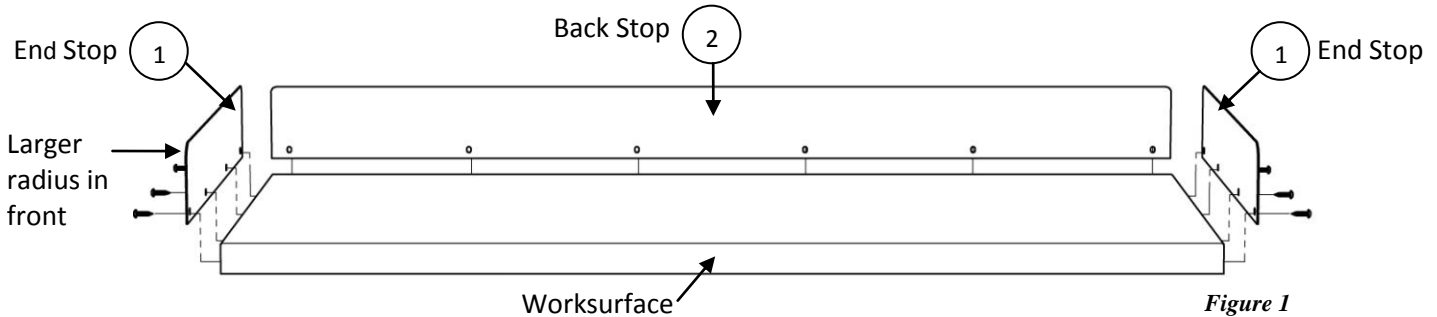

Figure 1

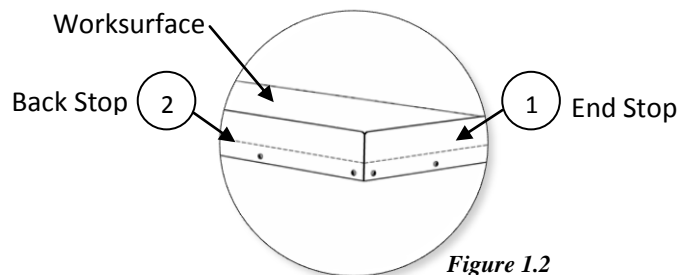



Figure 1.2

### Tools Required:

- Power drill
- 3/16" drill bit
- #2 phillips drill bit
- Center punch
- Pencil
- Safety glasses

Components		
Hardware	Description	Part Number
	#14 x 1" phillips pan head screw	A122845

### 1.1 Assembling End Stops

1. Orient the end stop ① so the larger corner radius is toward the front of the worksurface. (See figure 1)
2. Align the bottom edge of the end stop ① with the bottom edge of the worksurface. Align the rear edge of the end stop ① with the rear corner of the worksurface. (See figure 1.2)
3. Mark hole locations using the end stop ① as a template. Center punch the hole locations and drill 3/16" diameter pilot holes 1 1/4" deep.
4. Attach the end stop with #14 x 1" long phillips pan head screws. (See figure 1)

### 1.2 Assembling Back Stops

1. Align the bottom edge of the back stop ② with the bottom edge of the worksurface (See figure 1.2). Center the back stop ② across the length of the worksurface.
2. Mark hole locations using the back stop ② as a template. Center punch the hole locations and drill 3/16" diameter pilot holes 1 1/4" deep.
3. Attach the back stop ② with #14 x 1" long phillips pan head screws. (See figure 1)

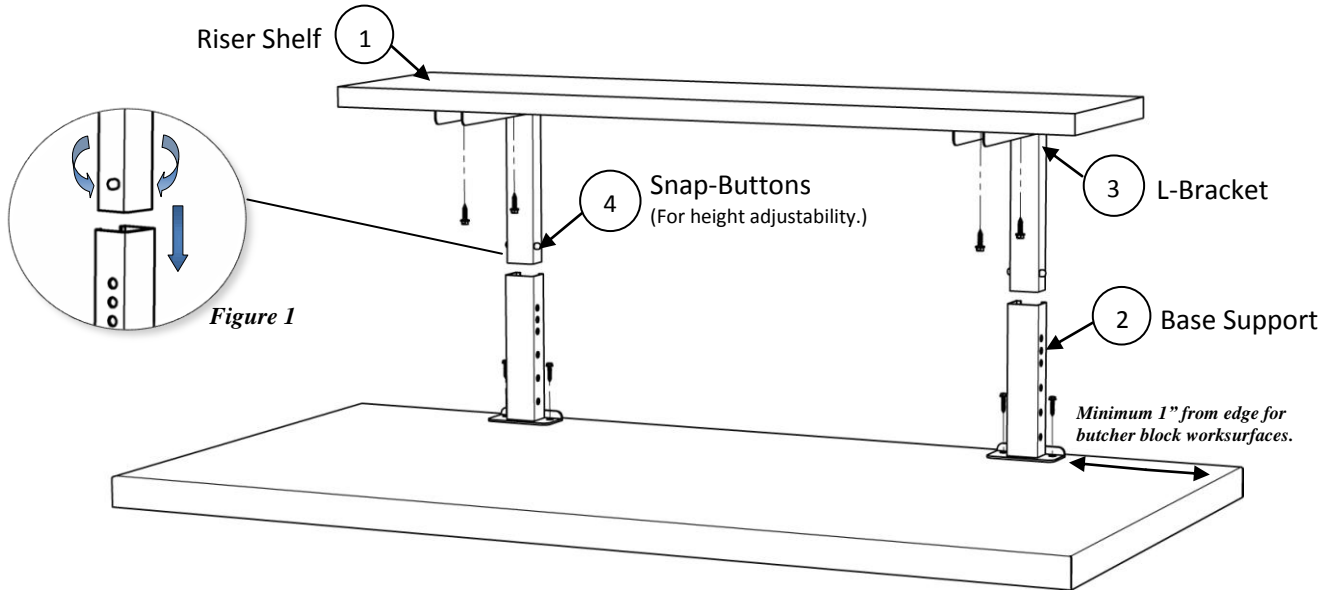

## 2. Assembling Adjustable Riser Shelf

*Note: Lista provides a third center support for 84"-96" wide laminate riser shelves and 90"-96" wide butcher block riser shelves.*



### Tools Required:

- Power drill
- $\frac{3}{16}$ " and #7 drill bit
- $\frac{7}{16}$ " and  $\frac{1}{2}$ " socket head with extension
- Center punch
- Pencil
- Safety glasses
- Tape measure

Components		
Hardware	Description	Part Number
	$\frac{5}{16}$ " x $1\text{-}\frac{1}{4}$ " hex flange screws	A112049
	#14 x $\frac{3}{4}$ " slotted hex head screw	A103111

### 2.1 Assembling Base Supports to Worksurface

1. Place the base support ② on the worksurface.
2. Align the rear edges of the base support ② with the rear edges of the worksurface.
3. Use the base support ② as a template and mark hole locations on the worksurface. Center punch the hole locations and drill #7 diameter pilot holes  $1\frac{1}{4}$ " deep. *Note: If installing the base supports ② to a butcher block worksurface, the hole locations should be at least 1" from the edge to the worksurface.*
4. Attach the base supports ② to the worksurface with  $\frac{5}{16}$ " x  $1\frac{1}{4}$ " long hex flange screws.

### 2.2 Assembling the Shelf to the L-Brackets

1. While holding the snap button down ④ slide the L-brackets ③ into the base supports ②. (See figure 1)
2. Center the riser shelf ① onto the L-brackets ③. Align the rear edges of riser shelf ① with the rear edges of the L-brackets ③.
3. Use the L-brackets ③ as a template and mark hole locations. Center punch and drill  $\frac{3}{16}$ " diameter pilot holes  $\frac{3}{4}$ " deep.
4. Attach the riser shelf ① to L-brackets ③ the using #14 x  $\frac{3}{4}$ " long slotted hex head screws.

*Note: If installing back and end stops see Section 1 for additional instructions.*

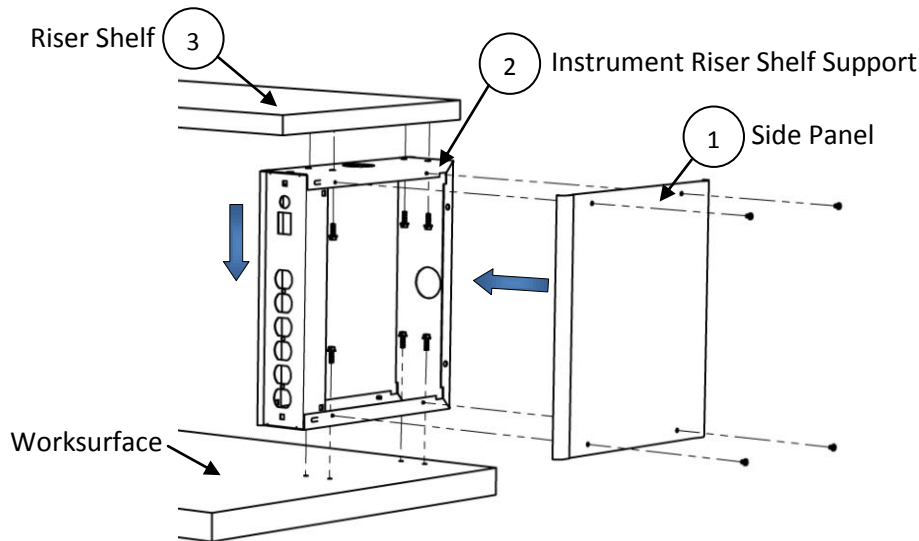

### 3. Assembling the Instrument Riser Shelf

*Note: Lista recommends using a third center support for 72"-96" wide laminate riser shelves. (For 72" wide laminate riser shelves a backstop OR third support may be suitable.) A third support is also recommended for 84"-96" wide butcher block riser shelves.*



#### Tools Required:

- Power drill
- 3/16" drill bit
- #2 phillips drill bit
- 7/16" socket head with extension
- Pencil
- Safety glasses
- Tape measure

Components		
Hardware	Description	Part Number
	#14 x 3/4" slotted hex head screw	A103111
	#10 - 32 x 3/4" phillips pan head screw	A109124

#### 3.1 Assembling the Riser Shelf to the Instrument Riser Shelf Supports

1. Place the riser shelf ③ upside down on worksurface.
2. Place the instrument riser shelf support ② upside down onto the riser shelf ③. Remove the side panels ① on the instrument riser shelf by unscrewing the #10 - 32 x 1/4" long phillips pan head screws.
3. Align the rear edge of the instrument riser shelf supports ② flush to the rear edge of the riser shelf ③.
4. Mark hole locations using the instrument riser shelf supports ② as a template. Drill 3/16" diameter pilot holes 3/4" deep.
5. Attach the riser shelf ③ to the instrument riser shelf supports ② with #14 x 3/4" long slotted hex head screws.

#### 3.2 Assembling the Instrument Riser Shelf Supports to the Worksurface

1. Upright the assembly and place on worksurface.
2. Align the instrument riser shelf supports ② rear edges flush with the rear edge of the worksurface.
3. Mark pilot hole locations using the instrument riser shelf supports ② as a template. Drill 3/16" diameter pilot holes 1" deep.
4. Attach instrument riser shelf supports ② to the worksurface with #14 x 3/4" long slotted hex head screws.
5. Replace the side panels ① on each instrument riser shelf support ② with #10 - 32 x 1/4" long phillips pan head screws.

*Note: If installing back and end stops see Section 1 for additional instructions.*

### 3. Assembling the Instrument Riser Shelf (contd.)

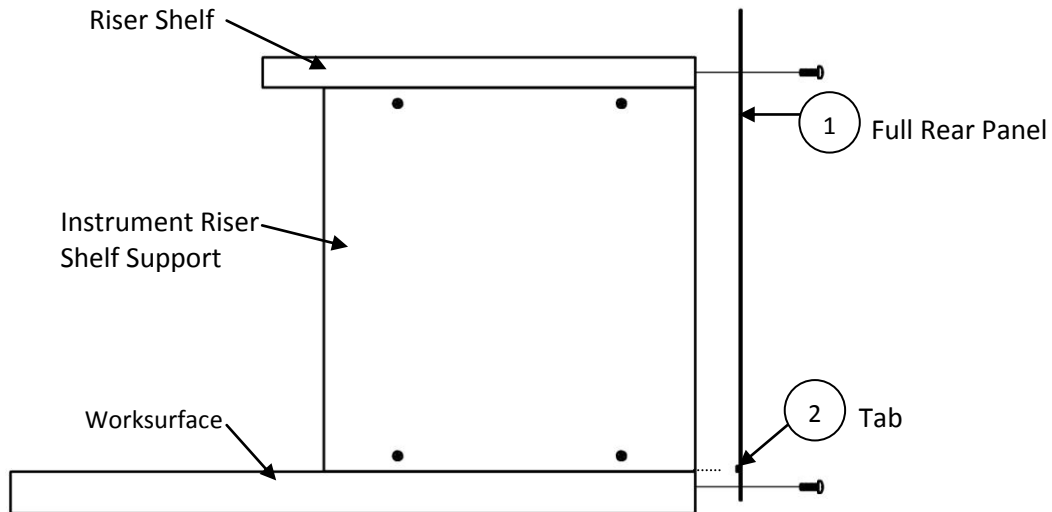

#### Tools Required:

- Power drill
- $\frac{3}{16}$ " drill bit
- #2 phillips drill bit
- Center punch
- Pencil
- Safety glasses

Components		
Hardware	Description	Part Number
	#14 x 1" phillips pan head screw	A122845

#### 3.3 Assembling Full Rear Panel (Optional)

1. Position the full rear panel ① against the back of the worksurface so that the tab ② rests on the worksurface. *Note: If attaching the optional full rear panel to an instrument riser shelf support ② with power, the large holes in the full rear panel should align with the holes in the back of each instrument riser shelf support ②.*
2. Mark the hole locations using the full rear panel ① as a template. Center punch the hole locations and drill  $\frac{3}{16}$ " diameter pilot holes  $1 \frac{1}{4}$ " deep.
3. Attach the full rear panel ① using #14 x 1" long phillips pan head screws.

## 4. Assembling the Stationary Riser Shelf

*Note: Lista provides two types of rear panels for the stationary riser shelf: Partial and Full*

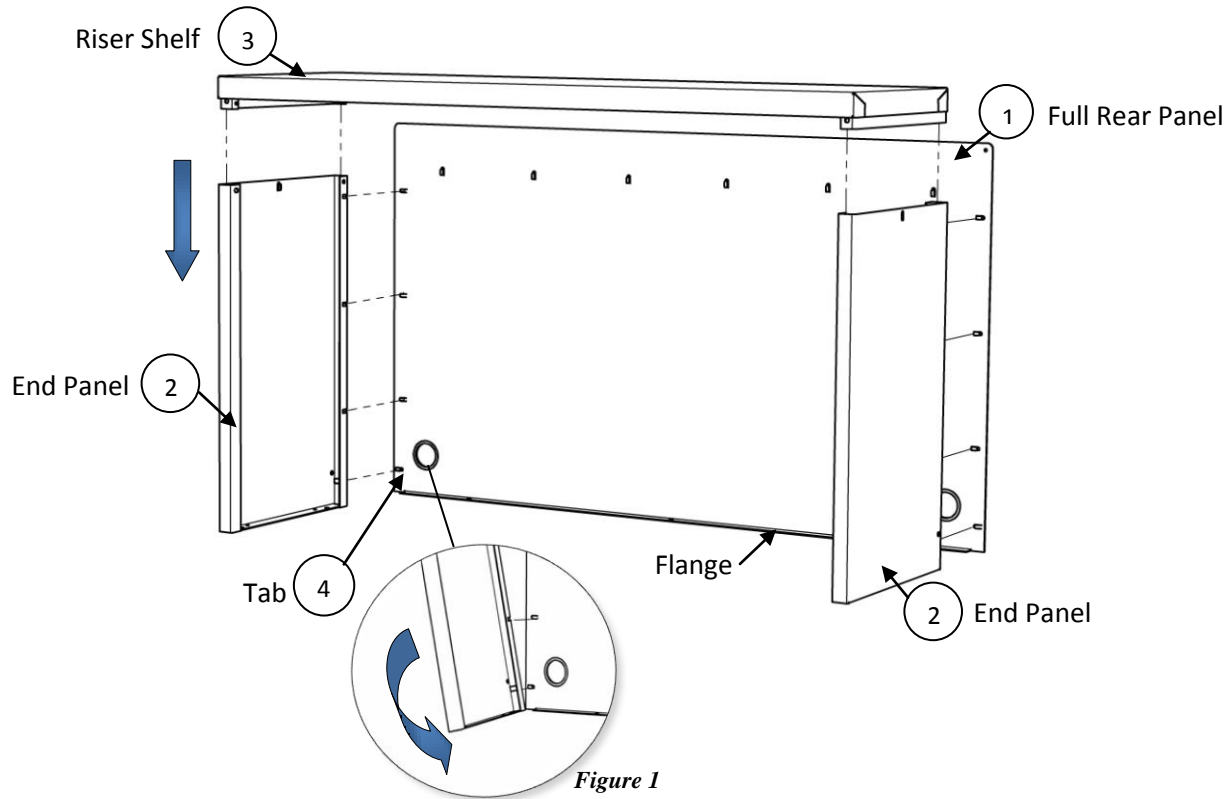

### Tools Required:

- Rubber mallet
- Safety glasses

#### 4.1 Assembling the Stationary Riser Shelf with Full Rear Panel

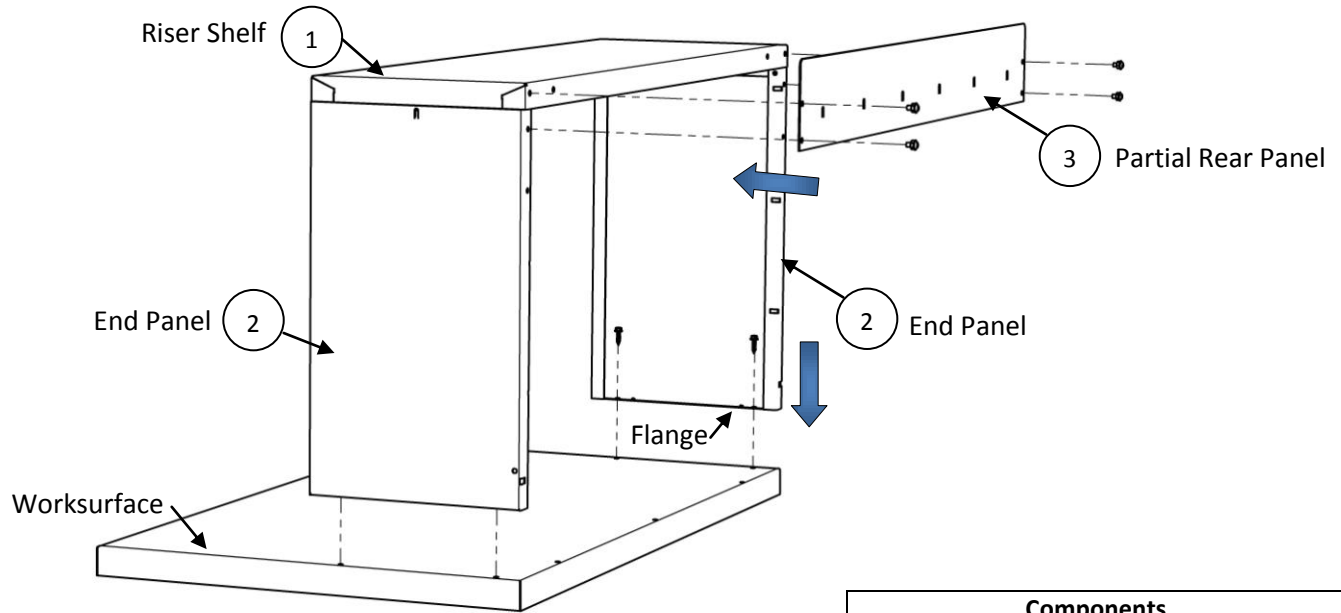

1. Lay the full rear panel ① down flange facing up on your worksurface.
2. Place the end panels ② down onto the full rear panel ① so that the bottom rectangular cutouts on the end panels ② fit over the bottom tabs ④ on the full rear panel ①. *Note: The flat-finished sides of the end panels should face out. All notches and holes should face the rear. (See figure 1)*
3. Rotate the end panels ② so the tabs on the full rear panel ① fit into the slots of the end panels ②. (See figure 1)
4. Upright the assembly and align the riser shelf ③ over the end panels ①.
5. Press the riser shelf ③ down into position.
6. See section 4.3 for final assembly.

## 4. Assembling the Stationary Riser Shelf (contd.)



### Tools Required:

- Power drill
- 3/16" drill bit
- #2 phillips drill bit
- 7/16" socket head with extension
- Pencil
- Rubber mallet
- Safety glasses

Components		
Hardware	Description	Part Number
	1/4" - 20 x 1/2" phillips head round screws	A100318
	1/4" - 20 kep nuts	A100314
	#14 x 3/4" hex head screw	A103111

### 4.2 Assembling the Stationary Riser Shelf with Partial Rear Panel

1. Place the riser shelf ① upside-down on the worksurface.
2. Orient the end panels ② so the flanges are facing up and all notches and holes face the rear.
3. Center the end panels ② inside the riser shelf ① and press them down into place.
4. Upright the assembly and align the partial rear panel ③ along the back of the riser shelf ① and end panels ② using the two holes at each end as a guide.
5. Attach the partial rear panel ③ with 1/4" - 20 x 1/2" long phillips head round screws and 1/4" - 20 kep nuts.
6. See section 4.3 for final assembly

### 4.3 Final Assembly: Assembling the Stationary Riser Shelf to the Worksurface

1. Center the assembly on the worksurface. Mark the pilot hole locations using the bottom flange of the end panel ② as a template. *Note: If installing a full rear panel also mark pilot holes located along its rear flange.*
2. Drill pilot holes 3/16" in diameter 1" deep.
3. Attach the stationary riser shelf with #14 x 3/4" long hex head screws.

Making Workspace Work™ is a trademark of Lista International Corporation.

Document Number: SD015A3 Rev 02

Print Date: June 2013

These instructions and other assembly instructions may be found on Lista International Corporation's web site, <http://www.listaintl.com>. For questions or Technical Support, please call 1-800-722-3020

This manual is proprietary information of Lista International Corporation. Unauthorized reproduction of any portion of this manual is prohibited without the written consent of Lista International Corporation. The material in this manual is for informational purposes only. It is subject to change without notice. Lista International Corporation assumes no responsibility for any typographical errors contained in this manual.

Lista International Corporation  
106 Lowland Street  
Holliston, MA 01746-2094  
Toll Free: (800) 722-3020  
Phone: (508) 429-1350  
E-mail: [sales@listaintl.com](mailto:sales@listaintl.com)  
Web: <http://www.listaintl.com/>

ISO 9001 Certified

© 2013 Lista International Corporation  
All rights reserved.